



F32 Spring

Features:

The YewdaleDefiant® F32 retractable insect screen with advanced slow-rise spring control ensures smooth and quiet operation. White metal universal brackets for secure top fixing with powder-coated extruded aluminium cassette and side guide channels. Rot-proof PVC coated fibreglass mesh is locked into the barrel and bottom bar profile.

Benefits:

The discreet yet attractive profile of the F32 roll-up system will complement the décor of many interiors. Coupled with the ease of the advanced spring operation, this system is perfectly suited to a wide range of both commercial and domestic applications. A strong focus on a trouble-free quality mechanism with high-grade nylon fittings ensures consistency of performance.

Specification:

The YewdaleDefiant® F32 retractable insect screen with advanced slow-rise spring operation as manufactured by Yewdale, +44 (0)1268 570900. Vandal resistant spring and decelerator mechanism is housed within white powder-coated aluminium cassette. Roll-up flame retardant, rot-proof PVC coated fibreglass mesh held securely inside guide channels and bottom bar. Supported by sturdy metal brackets.

Insect Screen Specification Guide

Model	Min / Max Width	Min / Max Drop	Max M ²	Cassette Size (HxD)	Side Channel Size (WxD)
F32	600 / 1800	400 / 2500	3.5	56 x 43 mm	40 x 22 mm

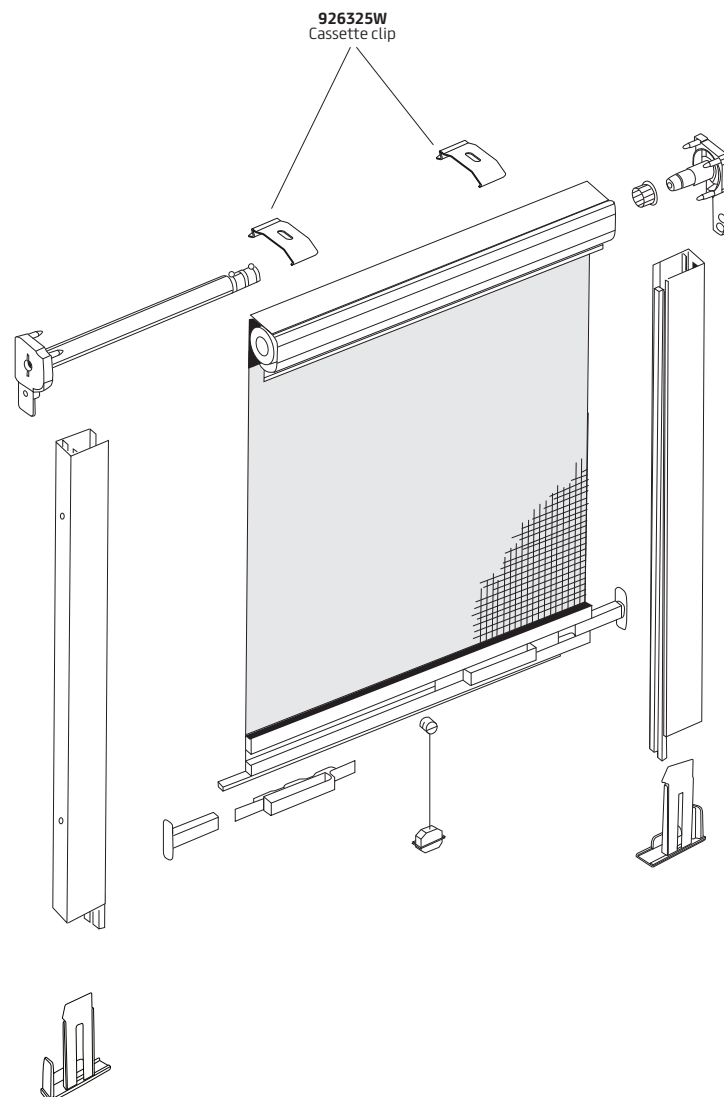

This product range comes with a full Lifetime Warranty as standard.